

LED Backlit Panel Light

Features

ETL: Suitable for damp locations. (Type IC rated)

DLC: Meet latest DLC 5.1 requirement.

Dimming: Isolate 0-10V dimming driver, 120-277V.

Long Lifespan: 50,000 hours, 5 years warranty.

Lens: High-transmission, diffuse lens have excellent distribution and uniformity.

Applications: Ultra slim backlit design for more applications.

3CCT selectable: 3500K/4000K/5000K.



Dimension

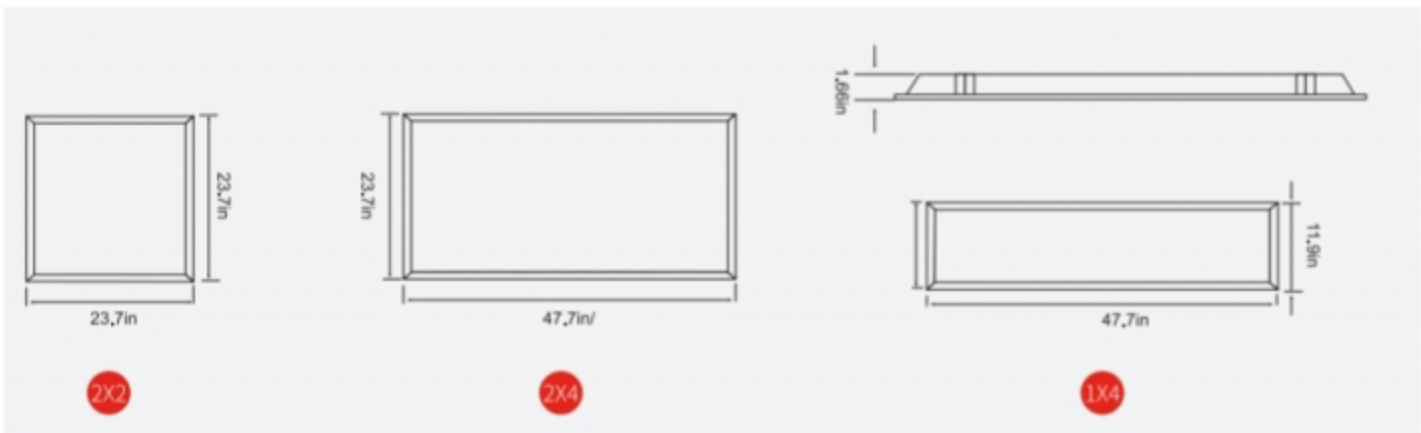

Photometric

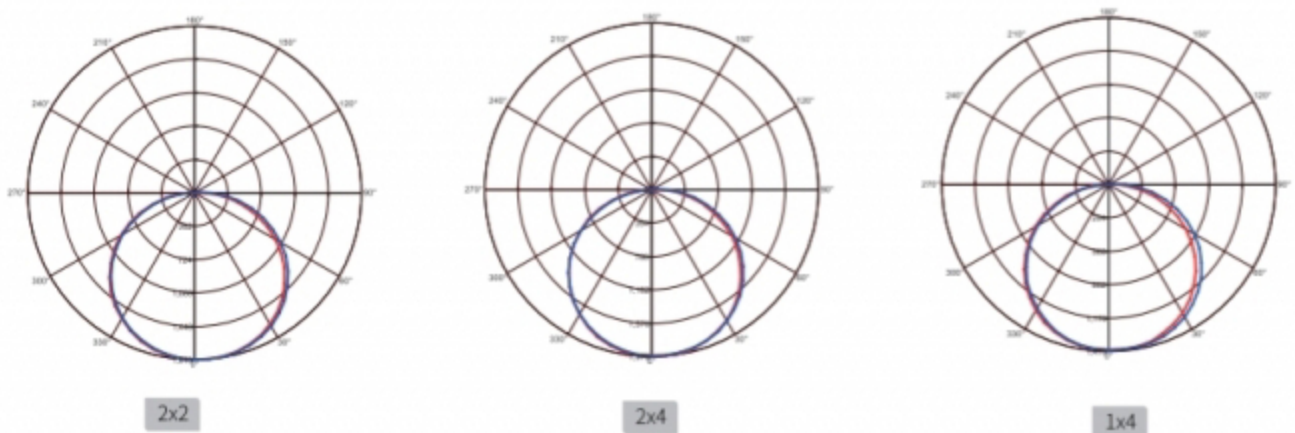

LED Backlit Panel Light

Specification

Catalog Number	Size	Input Voltage (V)	Lamp Watt (W)	Efficacy (Lumen/watt)	Lumen Output (lm)	CCT (K)	CRI	Life Time (Hrs)
LS26-GLFP 50W 2X2 CCT3	2X2	120-277VAC	50	110-120	5650/5900/5700	3500/4000/5000	>80	50,000
LS26-GLFP 50W 2X4 CCT3	2X4	120-277VAC	50	110-120	5750/6100/5800	3500/4000/5000	>80	50,000
LS26-GLFP 40W 1X4 CCT3	1X4	120-277VAC	40	110-120	4500/4700/4550	3500/4000/5000	>80	50,000
LS26-GLFP 50W 2X4/4K	2X4	120-277VAC	50	110-120	5750	4000	>80	50,000
LS26-GLFPE 50W 2X4/4K	2X4	120-277VAC	50	110-120	5750	4000	>80	50,000
LS26-GLFPE 50W 2X2 CCT3	2X2	120-277VAC	50	110-120	5600/5950/5700	3500/4000/5000	>80	50,000
LS26-GLFPE 50W 2X4 CCT3	2X4	120-277VAC	50	110-120	5750/6100/5800	3500/4000/5000	>80	50,000

** E = Emergency Backup Kit



2X2



2X4



1X4

Installation

Surface Mount



Connect three frames with connectors

Push the LED panel pigting into the channels

Recessed



Push the lamp front adown,put it into the ceiling channel

Please check if the lamp have been fixed in the ceiling channel

Suspension



Fix the under suspend rope in the lamp

Theard another side of the uppersuspend rope into the hasp