



LS-ELD-RG

Dual Circuit LED Exit Sign

Description Universal field-selectable single/double-face. Red and Green letter in one pack. It can be wall or ceiling mounted and suitable for Damp Locations.

FEATURES

- Long-life, high-intensity LEDs
- Fully illuminated 6" height with 3/4" stroke and chevron directional arrows
- UL-94-V0 flame-retardant, fire-resistant
- Injection-molded thermoplastic ABS housing
- Wall and ceiling mount
- AC input: 120/277/347V 60Hz
- DC input: 6-24V
- Operating Temperature: 0°C to 40°C (32°F to 104°F)
- 5 years warranty on all electronics and housing
- cSAus Listed for Damp Locations



PRODUCT IMAGES & DIMENSIONS

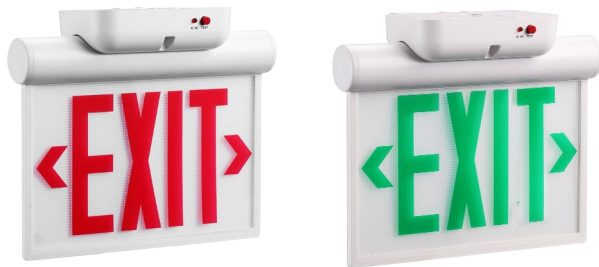

LS-ELD-RG

Dual Circuit LED Exit Sign, Red/
Green Letters

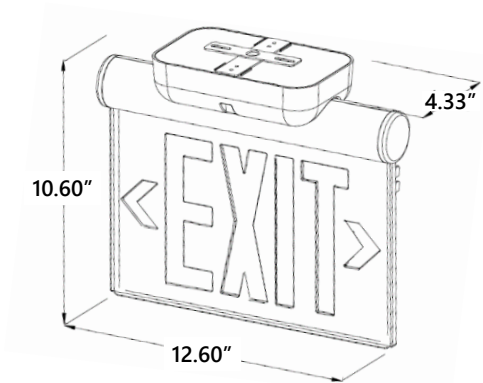

SPECIFICATIONS

PART NUMBER	WATTAGE	AC INPUT	DC INPUT	LETTER	FINISH	LISTING
LS-ELD-RG	1W	120/277/347V	6-24V	Red/Green	White	cSAus